

SPECIFICATION
FOR
LCM Module

MODULE No:	KD050WVRPA056
CUSTOMER:	

STARTEK	INITIAL	DATE
PREPARED BY		
CHECKED BY		
APPROVED BY		

CUSTOMER	INITIAL	DATE
APPROVED BY		

Contents

1. Block Diagram	5
2. Outline dimension	6
3. Input terminal Pin Assignment	7
4. LCD Optical Characteristics	9
4.1 Optical specification (Reflective).....	9
4.2 Optical specification (Transmittance).....	9
5. Electrical Characteristics	12
5.1 Absolute Maximum Rating.....	12
5.2 DC Electrical Characteristics.....	12
5.3 LED Backlight Characteristics.....	13
6. AC Characteristics	15
6.1 AC Timing characteristics.....	15
6.2 Timing Table.....	16
7. LCD Module Out-Going Quality Level	17
7.1 VISUAL & FUNCTION INSPECTION STANDARD	17
7.1.1 Inspection conditions.....	17
7.1.2 Definition.....	17
7.1.3 Sampling Plan.....	18
7.1.4 Criteria (Visual).....	19
8. Reliability Test Result	23
9. Cautions and Handling Precautions	24
9.1 Handling and Operating the Module.....	24
9.2 Storage and Transportation.....	24
10. Packing	25

Part. No	KD050WVRPA056	REV	V1.2	Page 3 of 25
	常备库存 Stock For Sale	长期供货 Long Time supply	支持小量 NO MOQ	品种齐全 In Full Range

*** Description**

This is a color active matrix TFT (Thin Film Transistor) LCD (liquid crystal display) that uses amorphous silicon TFT as a switching device. This model is composed of a transfective type TFT-LCD Panel, driver circuit, back-light unit. The resolution of a 5.0" TFT-LCD contains 800x480 pixels, and can display up to 16.7M colors.

*** Features**

General Information Items	Specification	Unit	Note
	Main Panel		
Display area(AA)	108(H)*64.8(V) (5.0inch)	mm	
Driver element	TFT active matrix	-	
Display colors	65K/262K16.7M	colors	
Number of pixels	800(RGB)*480	dots	
Pixel arrangement	RGB vertical stripe	-	
Pixel pitch	0.135(H)*0.135(V)	mm	
Viewing angle	6:00	o'clock	
Controller IC	HX8264+HX8664	-	
LCM Interface	16/18/24BIT RGB	-	
Display mode	transfective /Normally White	-	
Operating temperature	-20~+70	°C	
Storage temperature	-30~+80	°C	

*** Mechanical Information**

Item		Min.	Typ.	Max.	Unit	Note
Module size	Horizontal(H)	-	120.7	-	mm	
	Vertical(V)	-	75.9	-	mm	
	Depth(D)	-	2.95	-	mm	
Weight		-	50	-	g	

1. Block Diagram

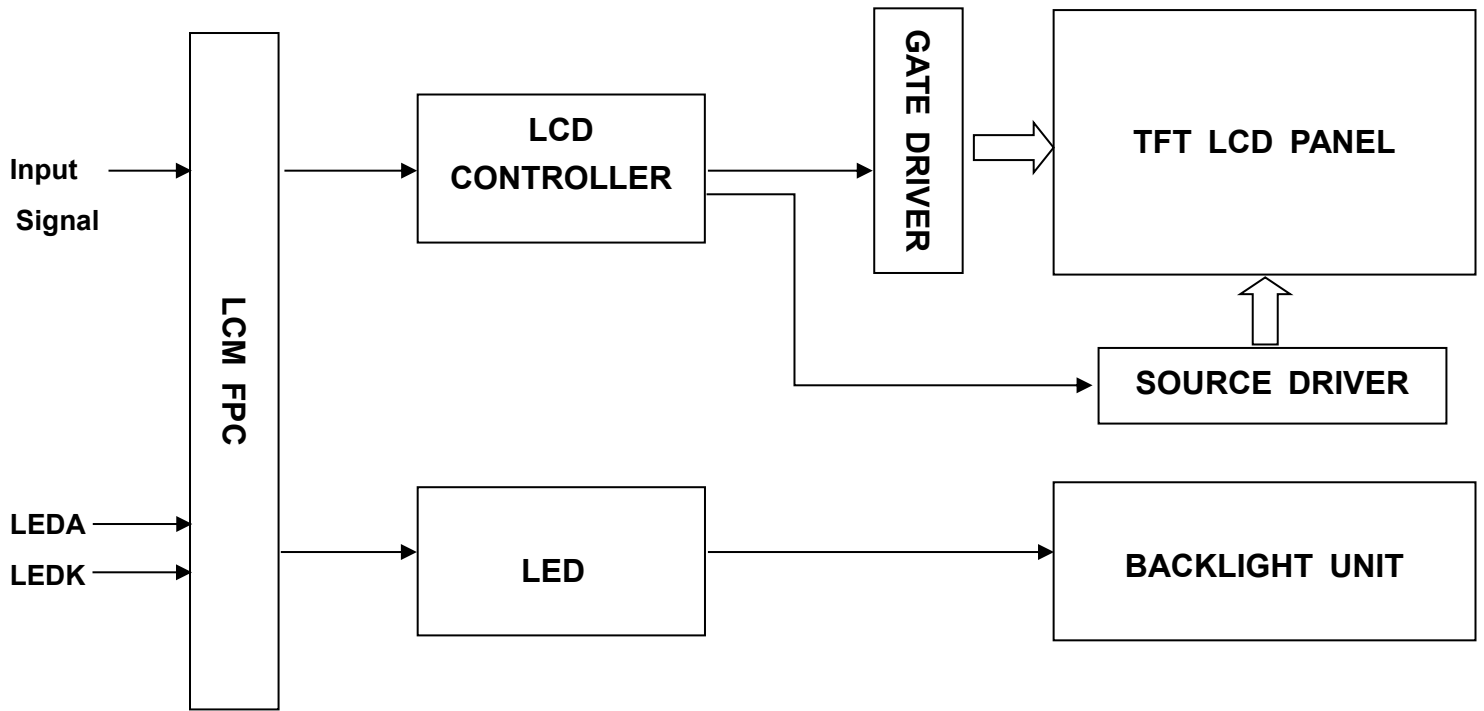

Part. No	KD050WVRPA056	REV	V1.2	Page 5 of 25
常备库存 Stock For Sale	长期供货 Long Time supply		支持小量 NO MOQ	品种齐全 In Full Range

3. Input terminal Pin Assignment

NO.	SYMBOL	DISCRIPTION	I/O
1	VLED-	Cathode pin OF backlight	P
2	VLED+	Anode pin of backlight	P
3	GND	Ground.	P
4	VDD	Supply voltage(3.3V).	P
5	R0	Red data input.	I
6	R1	Red data input.	I
7	R2	Red data input.	I
8	R3	Red data input.	I
9	R4	Red data input.	I
10	R5	Red data input.	I
11	R6	Red data input.	I
12	R7	Red data input.	I
13	G0	Green data input.	I
14	G1	Green data input.	I
15	G2	Green data input.	I
16	G3	Green data input.	I
17	G4	Green data input.	I
18	G5	Green data input.	I
19	G6	Green data input.	I
20	G7	Green data input.	I
21	B0	Blue data input.	I
22	B1	Blue data input.	I
23	B2	Blue data input.	I
24	B3	Blue data input.	I
25	B4	Blue data input.	I

26	B5	Blue data input.	I
27	B6	Blue data input.	I
28	B7	Blue data input.	I
29	GND	Ground.	P
30	PCLK	Clock signal. Latching data at the rising edge	I
31	DISP	Standby setting for testing, it should be connected to VDD in normal operation mode. If connected to GND, the IC is in standby mode.	I
32	HSYNC	Horizontal Sync input. Negative polarity.	I
33	VSYNC	Vertical Sync input. Negative polarity.	I
34	DE	Data input Enable. Active High to enable the data input Bus under "DE Mode".	I
35	NC	--	--
36	GND	Ground.	P
37	XR(NC)	Touch panel Right Glass Terminal	A/D
38	YD(NC)	Touch panel Bottom Film Terminal	A/D
39	XL(NC)	Touch panel LIFT Glass Terminal	A/D
40	YU(NC)	Touch panel Top Film Terminal	A/D

4. LCD Optical Characteristics

4.1 Optical specification (Reflective)

Item	Symbol	Condition	Min.	Typ.	Max.	Unit.	Note
White Reflectance (with Polarizer)	Rw (%)	Normal viewing angle	--	14.3	--	%	
Contrast Ratio	CR		--	20	--		(1)(2)
Response time	Rising		T _{R+T_F}	--	30	--	msec
	Falling	--					
Color Gamut	S(%)		--	10	--	%	
Color Filter Chromaticity	White	W _X	--	0.2926	--		(1)(4)
		W _Y	--	0.3349	--		CA-310
Viewing angle	Hor.	Θ _L	--	65	--	--	(1)(4)
		Θ _R	--	65	--		
	Ver.	Θ _U	--	65	--		
		Θ _D	--	65	--		

4.2 Optical specification (Transmittance)

Item	Symbol	Condition	Min.	Typ.	Max.	Unit.	Note
White Reflectance (with Polarizer)	Rw (%)	Normal viewing angle	--	0.25		%	
Contrast Ratio	CR		--	35	--		(1)(2)
Response time	Rising		T _{R+T_F}	--	25	--	msec
	Falling	--					
Color Gamut	S(%)		--	3.5	--	%	
Color Filter Chromaticity	White	W _X	0.2566	0.2966	0.3366		(1)(4) CA-310
		W _Y	0.2586	0.2986	0.3386		
	Red	R _X	0.3108	0.3508	0.3908		
		R _Y	0.2553	0.2953	0.3353		
	Green	G _X	0.2647	0.3047	0.3447		
		G _Y	0.3018	0.3418	0.3818		
	Blue	B _X	0.1816	0.2216	0.2616		
		B _Y	0.1837	0.2237	0.2637		

Part. No	KD050WVRPA056	REV	V1.2	Page 9 of 25
常备库存 Stock For Sale	长期供货 Long Time supply	支持小量 NO MOQ	品种齐全 In Full Range	

Viewing angle	Hor.	Θ_L	CR>10	--	65	--	(1)(4)
		Θ_R		--	65	--	
	Ver.	Θ_U		--	35	--	
		Θ_D		--	55	--	
Option View Direction		6 O'clock					

*The data comes from the LCD specification.

Measuring Condition

Measuring surrounding : dark rooms
 Ambient temperature : $25 \pm 2^\circ\text{C}$
 15min. warm-up time.

Measuring Equipment

FPM520 of Westar Display technologies, INC., which utilized SR-3 for Chromaticity and BM-5A for other optical characteristics.

Note (1): Definition of Viewing Angle :

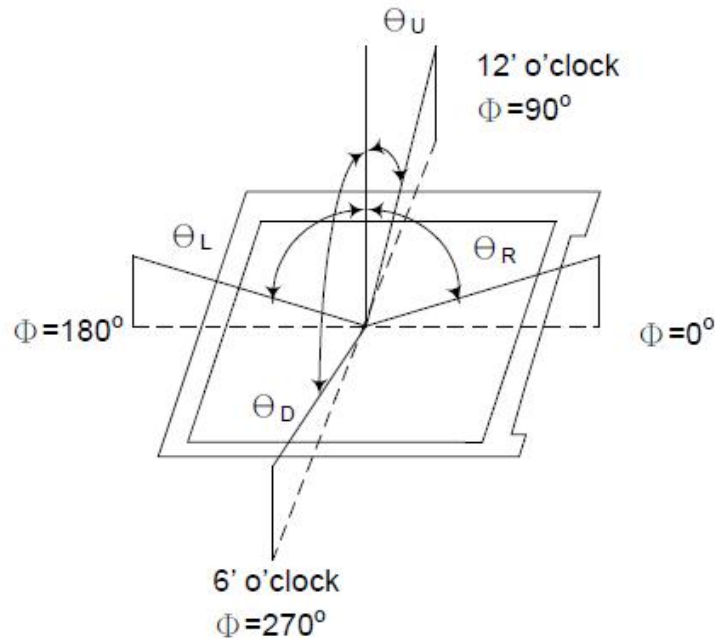

Part. No	KD050WVRPA056	REV	V1.2	Page 10 of 25
常备库存 Stock For Sale	长期供货 Long Time supply	支持小量 NO MOQ	品种齐全 In Full Range	

Note (2): Definition of Contrast Ratio(CR) :measured at the center point of panel

$$CR = \frac{\text{Luminance with all pixels white}}{\text{Luminance with all pixels black}}$$

Note (3): Response Time

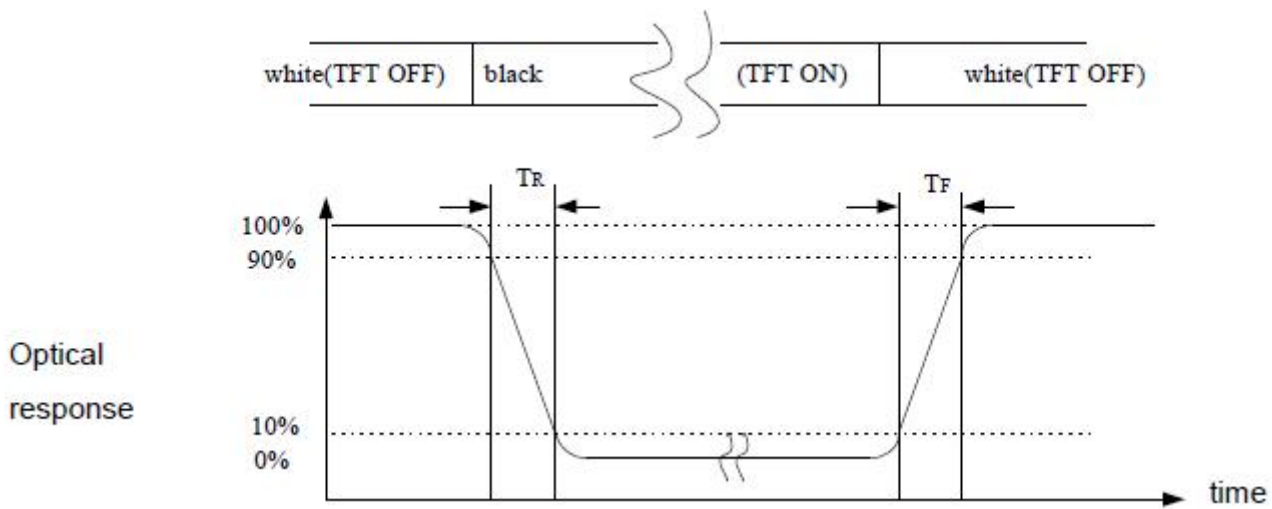

Note (4): Definition of optical measurement setup

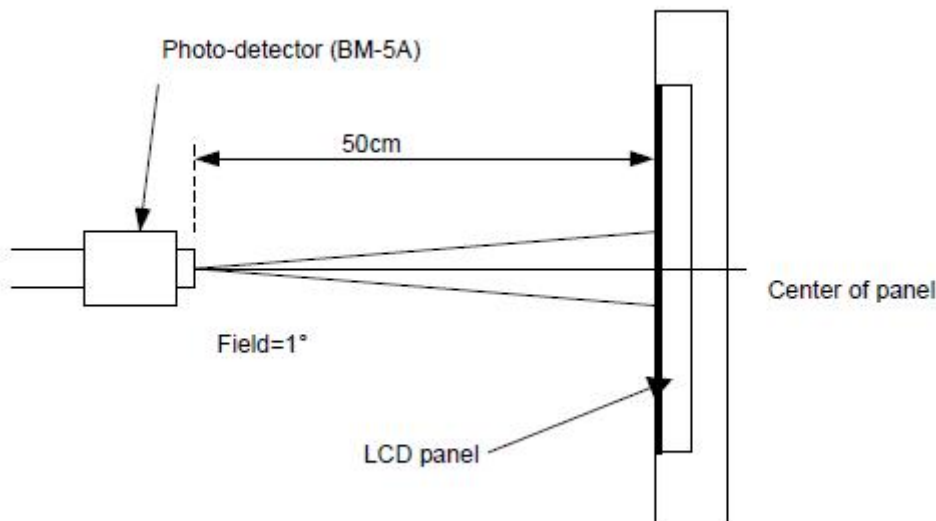

Part. No	KD050WVRPA056	REV	V1.2	Page 11 of 25
常备库存 Stock For Sale	长期供货 Long Time supply		支持小量 NO MOQ	品种齐全 In Full Range

5. Electrical Characteristics

5.1 Absolute Maximum Rating

Characteristics	Symbol	Min.	Max.	Unit	Note
Digital Supply Voltage	VDD	-0.5	3.96	V	Note1
Operating temperature	T _{OP}	-20	+70	°C	
Storage temperature	T _{ST}	-30	+80	°C	

NOTE1: If the absolute maximum rating of even is one of the above parameters is exceeded even momentarily, the quality of the product may be degraded. Absolute maximum ratings, therefore, specify the values exceeding which the product may be physically damaged. Be sure to use the product within the range of the absolute maximum ratings.

5.2 DC Electrical Characteristics

Characteristics	Symbol	Min.	Typ.	Max.	Unit	Note
Digital Supply Voltage	VDD	2.7	3.3	3.6	V	
Normal mode Current	IDD	--	105	210	mA	
Level input voltage	V _{IH}	0.7VDD		VDD	V	
	V _{IL}	GND		0.3VDD	V	
Level output voltage	V _{OH}	VDD-0.4		--	V	
	V _{OL}	GND		GND+0.4	V	

5.3 LED Backlight Characteristics

The back-light system is edge-lighting type with 12 chips LED

Item	Symbol	Min.	Typ.	Max.	Unit	Note
Forward Current	I_F	30	40	--	mA	Note3
Forward Voltage	V_F	16.8	--	19.6	V	
LCM Luminance	LV	23	28	--	cd/m ²	Note4
LED life time	Hr	50000	--	--	Hours	Note1,2
Uniformity	Avg	80	--	--	%	Note4

Note1: LED life time (Hr) can be defined as the time in which it continues to operate under the condition:

$T_a=25\pm 3\text{ }^\circ\text{C}$, typical IL value indicated in the above table until the brightness becomes less than 50%.

Note 2: The “LED life time” is defined as the module brightness decrease to 50% original brightness at

$T_a=25\text{ }^\circ\text{C}$ and $I_L=40\text{ mA}$. The LED lifetime could be decreased if operating I_L is larger than 40mA. The constant current driving method is suggested.

Note 3: Based on the consideration of the display effect, if the backlight is used, it is recommended to use

15~20mA for the input current(Reduce current usage).

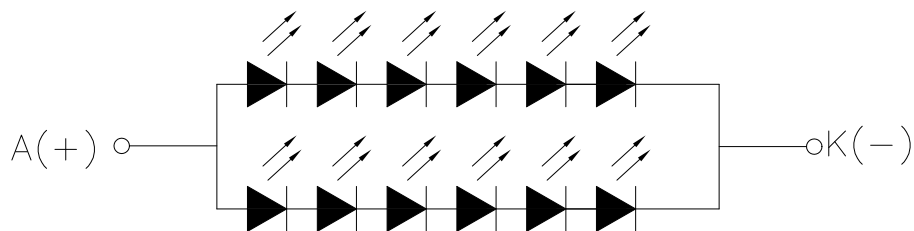

LED (B/L) CIRCUIT

Part. No	KD050WVRPA056	REV	V1.2	Page 13 of 25
常备库存 Stock For Sale	长期供货 Long Time supply	支持小量 NO MOQ	品种齐全 In Full Range	

Note (4) Luminance Uniformity of these 9 points is defined as below:

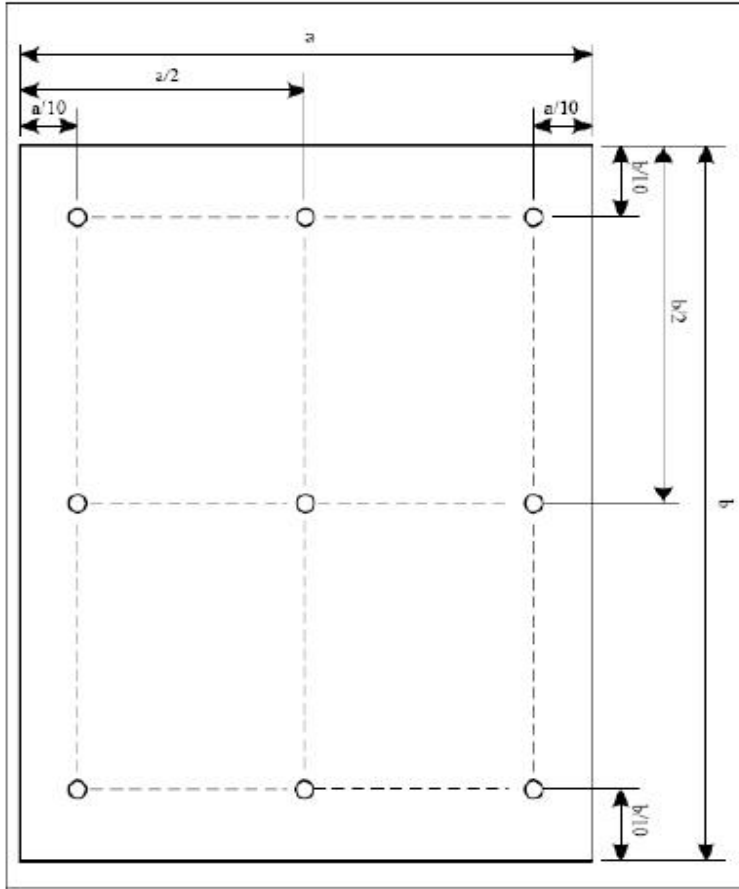

$$\text{Uniformity} = \frac{\text{minimum luminance in 9 points (1-9)}}{\text{maximum luminance in 9 points (1-9)}}$$

$$\text{Luminance} = \frac{\text{Total Luminance of 9 points}}{9}$$

Part. No	KD050WVRPA056	REV	V1.2	Page 14 of 25
常备库存 Stock For Sale	长期供货 Long Time supply	支持小量 NO MOQ	品种齐全 In Full Range	

6. AC Characteristics

6.1 AC Timing characteristics

Parameter	Symbol	Spec.			Unit
		Min.	Typ.	Max.	
HS setup time	T_{hst}	8	-	-	ns
HS hold time	T_{hhd}	8	-	-	ns
VS setup time	T_{vst}	8	-	-	ns
VS hold time	T_{vhd}	8	-	-	ns
Data setup time	T_{dsu}	8	-	-	ns
Data hold time	T_{dhd}	8	-	-	ns
DE setup time	T_{esu}	8	-	-	ns
DE hold time	T_{ehd}	8	-	-	ns
VDD Power On Slew rate	T_{POR}	-	-	20	ms
RSTB pulse width	T_{Rst}	10	-	-	μ s
CLKIN cycle time	T_{cph}	20	-	-	ns
CLKIN pulse duty	T_{cwh}	40	50	60	%
Output stable time	T_{sst}	-	-	6	μ s

6.2 Timing Table

The display operation via the RGB interface is synchronized with the VSYNC, HSYNC, and DOTCLK signals. The data can be written only within the specified area with low power consumption by using window address function. The back porch and front porch are used to set the RGB interface timing.

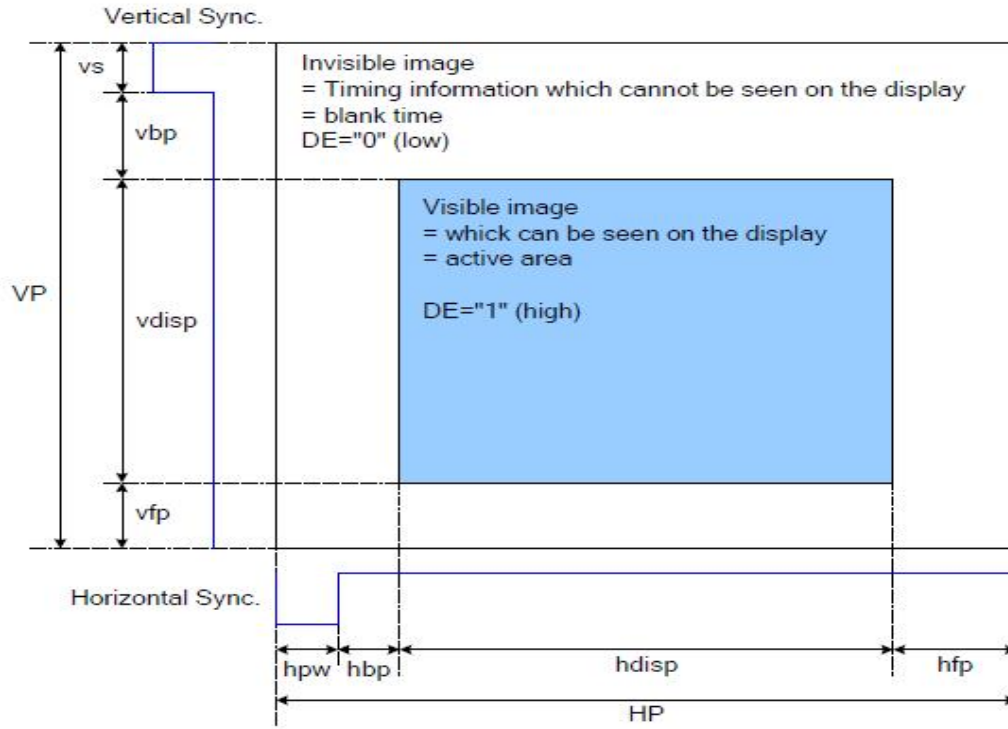

DRAM Access Area by RGB Interface

Please refer to the following table for the setting limitation of RGB interface signals.

Parameter	Symbol	Min.	Typ.	Max.	Unit
DCLK frequency	FCLK	--	30	--	MHz
Horizontal Address	hdisp	--	800	--	Clock
Horizontal Sync. Width	hpw	1	10	--	Clock
Horizontal Sync. Back Porch	hbp	1	88	--	Clock
Horizontal Sync. Front Porch	hfp	1	40	--	Clock
Vertical Address	vdisp	-	480	--	Line
Vertical Sync. Width	vs	1	8	--	Line
Vertical Sync. Back Porch	vbp	1	32	--	Line
Vertical Sync. Front Porch	vfp	1	13	--	Line
Frame-Rate	FR	--	60	--	Hz

Part. No	KD050WVRPA056	REV	V1.2	Page 16 of 25
常备库存 Stock For Sale	长期供货 Long Time supply	支持小量 NO MOQ	品种齐全 In Full Range	

7. LCD Module Out-Going Quality Level

7.1 VISUAL & FUNCTION INSPECTION STANDARD

7.1.1 Inspection conditions

Inspection performed under the following conditions is recommended.

Temperature : $25\pm 5^{\circ}\text{C}$

Humidity : $65\%\pm 10\%\text{RH}$

Viewing Angle : Normal viewing Angle.

Illumination: Single fluorescent lamp (1000 to 1200Lux)

Viewing distance:30-50cm

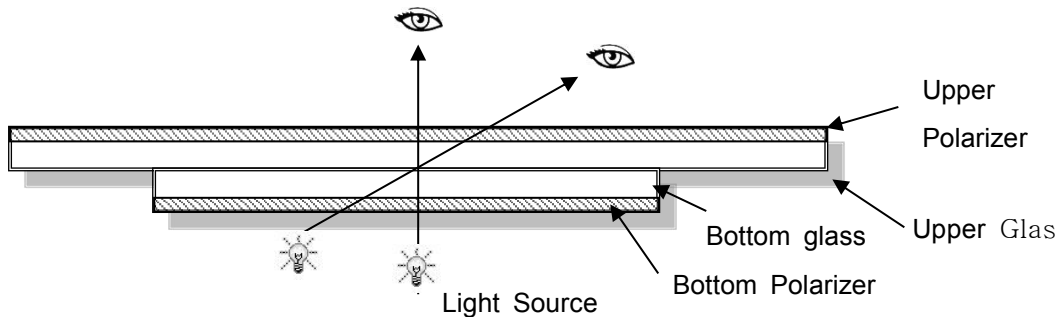

7.1.2 Definition

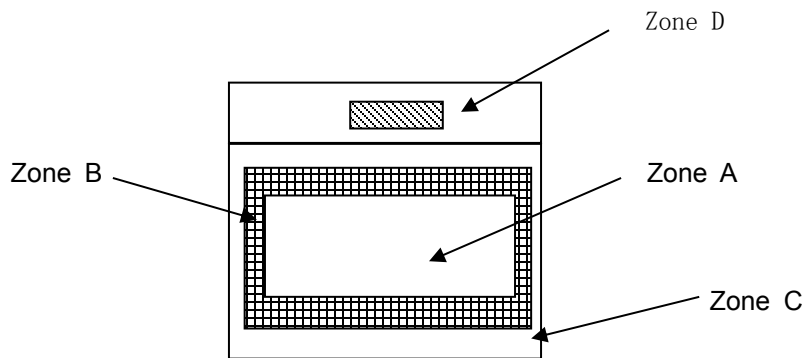

Zone A : Effective Viewing Area(Character or Digit can be seen)

Zone B : Viewing Area except Zone A

Zone C : Outside (Zone A+Zone B) which can not be seen after assembly by customer .)

Zone D : IC Bonding Area

Note:As a general rule ,visual defects in Zone C can be ignored when it doesn't effect product function or appearance after assembly by customer

Part. No	KD050WVRPA056	REV	V1.2	Page 17 of 25
常备库存 Stock For Sale	长期供货 Long Time supply	支持小量 NO MOQ	品种齐全 In Full Range	

7.1.3 Sampling Plan

According to GB/T 2828-2003 ; , normal inspection, Class II

AQL:

Major defect	Minor defect
0.65	1.5

LCD: Liquid Crystal Display , LCM: Liquid Crystal Module

No	Items to be inspected	Criteria	Classification of defects
1	Functional defects	1) No display, Open or miss line 2) Display abnormally, Short 3) Backlight no lighting, abnormal lighting. etc...	Major
2	Missing	Missing components and etc...	
3	Outline dimension	Overall outline dimension beyond the drawing is not allowed, deformation and etc...	
4	Color tone	Color unevenness, refer to limited sample	Minor
5	Spot/Line defect	Light dot, Dim spot, (Note1) Polarizer Air Bubble, Polarizer accidented spot and etc...	
6	Soldering appearance	Good soldering , Peeling off is not allowed and etc...	
7	LCD/Polarizer	Black/White spot/line, scratch, crack, etc.	

Note1: a) Light dot: Dots appear bright and unchanged in size in which LCD panel is displaying under black pattern.

b) Dim dot: Dots appear dark and unchanged in size in which LCD panel is displaying under pure red, green, blue picture.

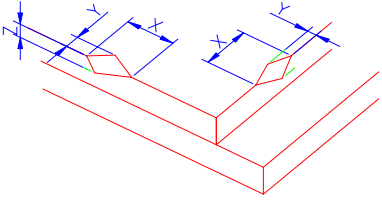
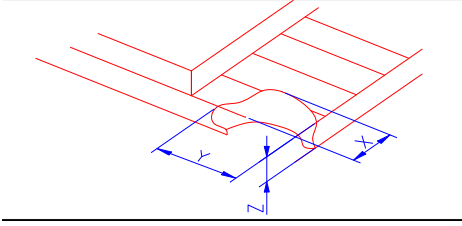
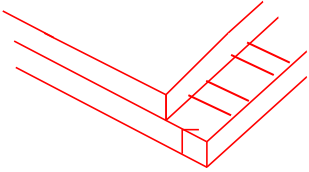

Part. No	KD050WVRPA056	REV	V1.2	Page 18 of 25
常备库存 Stock For Sale	长期供货 Long Time supply	支持小量 NO MOQ	品种齐全 In Full Range	

7.1.4 Criteria (Visual)

Number	Items	Criteria(mm)						
1.0 LCD Crack/Broken NOTE: X: Length Y: Width Z: Height L: Length of IT O, T: Height of LCD	(1) The edge of LCD broken	 <table border="1" data-bbox="756 667 1455 815"> <thead> <tr> <th>X</th> <th>Y</th> <th>Z</th> </tr> </thead> <tbody> <tr> <td>≤3.0mm</td> <td><Inner border line of the seal</td> <td>≤T</td> </tr> </tbody> </table>	X	Y	Z	≤3.0mm	<Inner border line of the seal	≤T
X	Y	Z						
≤3.0mm	<Inner border line of the seal	≤T						
	(2)LCD corner broken	 <table border="1" data-bbox="836 1124 1375 1223"> <thead> <tr> <th>X</th> <th>Y</th> <th>Z</th> </tr> </thead> <tbody> <tr> <td>≤3.0mm</td> <td>≤L</td> <td>≤T</td> </tr> </tbody> </table>	X	Y	Z	≤3.0mm	≤L	≤T
X	Y	Z						
≤3.0mm	≤L	≤T						
	(3) LCD crack	 <p style="text-align: center;">Crack Not allowed</p>						

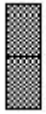
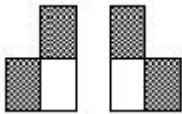

2.0	Spot defect	① light dot (black/white spot , pinhole, stain, etc.)			
	<p style="text-align: center;">$\Phi = (X+Y)/2$</p>	Zone	Acceptable Qty		
		Size (mm)	A	B	C
		$\Phi \leq 0.15$	Ignore		
		$0.15 < \Phi \leq 0.25$	3(distance ≥ 10 mm)		
	$0.25 < \Phi \leq 0.4$	2(distance ≥ 10 mm)			
	$\Phi > 0.4$	0			
		② Dim spot (light leakage, dent, dark spot, etc)			
		Zone	Acceptable Qty		
		Size (mm)	A	B	C
		$\Phi \leq 0.15$	Ignore		
		$0.15 < \Phi \leq 0.25$	3(distance ≥ 10 mm)		
		$0.25 < \Phi \leq 0.4$	2(distance ≥ 10 mm)		
		$\Phi > 0.4$	0		
		③ Polarizer accidented spot			
		Zone	Acceptable Qty		
		Size (mm)	A	B	C
		$\Phi \leq 0.2$	Ignore		
		$0.2 < \Phi \leq 0.5$	2(distance ≥ 10 mm)		
		$\Phi > 0.5$	0		
		④ Polarizer Bubble			
		Zone	Acceptable Qty		
		Size (mm)	A	B	C
		$\Phi \leq 0.2$	Ignore		
		$0.2 < \Phi \leq 0.4$	2(distance ≥ 10 mm)		
		$0.4 < \Phi \leq 0.5$	1		
		$\Phi > 0.5$	0		

3.0	LCD Pixel defect	<p>Pixel bad points</p> <table border="1"> <thead> <tr> <th data-bbox="539 309 730 360">Item</th> <th data-bbox="730 309 1246 360">Zone A</th> <th data-bbox="1246 309 1497 360">Acceptable Qt</th> </tr> </thead> <tbody> <tr> <td data-bbox="539 360 730 521" rowspan="3">Bright dot</td> <td data-bbox="730 360 1246 416">Random</td> <td data-bbox="1246 360 1497 416">N≤2</td> </tr> <tr> <td data-bbox="730 416 1246 472">2 dots adjacent</td> <td data-bbox="1246 416 1497 472">N≤0</td> </tr> <tr> <td data-bbox="730 472 1246 521">3 dots adjacent</td> <td data-bbox="1246 472 1497 521">N≤0</td> </tr> <tr> <td data-bbox="539 521 730 689" rowspan="3">Dark dot</td> <td data-bbox="730 521 1246 577">Random</td> <td data-bbox="1246 521 1497 577">N≤3</td> </tr> <tr> <td data-bbox="730 577 1246 633">2 dots adjacent</td> <td data-bbox="1246 577 1497 633">N≤0</td> </tr> <tr> <td data-bbox="730 633 1246 689">3 dots adjacent</td> <td data-bbox="1246 633 1497 689">N≤0</td> </tr> <tr> <td data-bbox="539 689 730 1003">Distance</td> <td data-bbox="730 689 1246 1003"> 1. Minimum Distance Between Bright dots. 2. Minimum Distance Between dark dots 3. Minimum Distance Between dark and bright dot. </td> <td data-bbox="1246 689 1497 1003">5mm</td> </tr> <tr> <td colspan="2" data-bbox="539 1003 1246 1059">Total bright and dark dot</td> <td data-bbox="1246 1003 1497 1059">N≤4</td> </tr> </tbody> </table> <p>Note:</p> <p>A) Bright dot: Dots appear bright and unchanged in size in which LCD panel is displaying under black pattern.</p> <p>B) Dark dot: Dots appear dark and unchanged in size in which LCD panel is displaying under pure red, green, blue picture.</p> <p>C) 2 dot adjacent = 1 pair = 2 dots</p> <p>Picture:</p> <div style="display: flex; justify-content: space-around; align-items: flex-start;"> <div style="text-align: center;">  <p>2 dot adjacent</p> </div> <div style="text-align: center;">  <p>2 dot adjacent</p> </div> <div style="text-align: center;">  <p>2 dot adjacent (vertical)</p> </div> <div style="text-align: center;">  <p>2 dot adjacent (slant)</p> </div> </div>	Item	Zone A	Acceptable Qt	Bright dot	Random	N≤2	2 dots adjacent	N≤0	3 dots adjacent	N≤0	Dark dot	Random	N≤3	2 dots adjacent	N≤0	3 dots adjacent	N≤0	Distance	1. Minimum Distance Between Bright dots. 2. Minimum Distance Between dark dots 3. Minimum Distance Between dark and bright dot.	5mm	Total bright and dark dot		N≤4
Item	Zone A	Acceptable Qt																							
Bright dot	Random	N≤2																							
	2 dots adjacent	N≤0																							
	3 dots adjacent	N≤0																							
Dark dot	Random	N≤3																							
	2 dots adjacent	N≤0																							
	3 dots adjacent	N≤0																							
Distance	1. Minimum Distance Between Bright dots. 2. Minimum Distance Between dark dots 3. Minimum Distance Between dark and bright dot.	5mm																							
Total bright and dark dot		N≤4																							

4.0	Line defect (LCD /Polarizer backlight black/white line, scratch, stain)  W: width, L : length N : Count	<table border="1"> <thead> <tr> <th rowspan="2">Width(mm)</th> <th rowspan="2">Length(m)</th> <th colspan="3">Acceptable Qty</th> </tr> <tr> <th>A</th> <th>B</th> <th>C</th> </tr> </thead> <tbody> <tr> <td>$\Phi \leq 0.05$</td> <td>Ignore</td> <td colspan="2">Ignore</td> <td rowspan="3">Ignore</td> </tr> <tr> <td>$0.05 < W \leq 0.06$</td> <td>$L \leq 5.0$</td> <td colspan="2">$N \leq 3$</td> </tr> <tr> <td>$0.06 < W \leq 0.08$</td> <td>$L \leq 4.0$</td> <td colspan="2">$N \leq 2$</td> </tr> <tr> <td>$W > 0.08$</td> <td colspan="4">Define as spot defect</td> </tr> </tbody> </table>	Width(mm)	Length(m)	Acceptable Qty			A	B	C	$\Phi \leq 0.05$	Ignore	Ignore		Ignore	$0.05 < W \leq 0.06$	$L \leq 5.0$	$N \leq 3$		$0.06 < W \leq 0.08$	$L \leq 4.0$	$N \leq 2$		$W > 0.08$	Define as spot defect			
		Width(mm)			Length(m)	Acceptable Qty																						
			A	B		C																						
		$\Phi \leq 0.05$	Ignore	Ignore		Ignore																						
		$0.05 < W \leq 0.06$	$L \leq 5.0$	$N \leq 3$																								
$0.06 < W \leq 0.08$	$L \leq 4.0$	$N \leq 2$																										
$W > 0.08$	Define as spot defect																											
5.0	Electronic Components SMT.	Not allow missing parts, solderless connection, cold solder joint, mismatch, The positive and negative polarity opposite																										
6.0	Display color & Brightness.	1. Color: Measuring the color coordinates, The measurement standard according to the datasheet or samples. 2. Brightness: Measuring the brightness of White screen, The measurement standard according to the datasheet or Samples.																										
7.0	LCD Mura/Waving/ Hot spot	Not visible through 5% ND filter in 50% gray or judge by limit sample if necessary.																										

Criteria (functional items)

Number	Items	Criteria (mm)
1	No display	Not allowed
2	Missing segment	Not allowed
3	Short	Not allowed
4	Backlight no lighting	Not allowed

8. Reliability Test Result

Item	Condition	Inspection after test
High Temperature Operating	70°C,96H	Inspection after 2~4hours storage at room temperature, the sample shall be free from defects: 1.Air bubble in the LCD; 2.Non-display; 3.Missing segments/line; 4.Glass crack; 5.Current IDD is twice higher than initial value.
Low Temperature Operating	-20°C, 96HR	
High Temperature Storage	80°C, 96HR	
Low Temperature Storage	-30°C, 96HR	
High Temperature & High	+60°C, 90% RH ,96 hours.	
Thermal Shock (Non-operation)	-10°C,30 min ↔ +60°C,30 min, Change time:5min 20CYC.	
ESD test	C=150pF, R=330,5points/panel Air:±8KV, 5times; Contact:±6KV, 5 times; (Environment: 15°C~35°C, 30%~60%).	
Vibration (Non-operation)	Frequency range:10~55Hz, Stroke:1.5mm Sweep:10Hz~55Hz~10Hz 2 hours for each direction of X.Y.Z. (6 hours for total) (Package condition).	
Box Drop Test	1 Corner 3 Edges 6 faces,80cm(MEDIUM BOX)	

Remark:

- The test samples should be applied to only one test item.
- Sample size for each test item is 5~10pcs.
- For Damp Proof Test, Pure water(Resistance > 10MΩ) should be used.
- In case of malfunction defect caused by ESD damage, if it would be recovered to normal state after resetting, it would be judged as a good part.
- Failure Judgment Criterion: Basic Specification, Electrical Characteristic, Mechanical Characteristic, Optical Characteristic.
- The color fading mura of polarizing filter should not care.

Part. No	KD050WVRPA056	REV	V1.2	Page 23 of 25
常备库存 Stock For Sale	长期供货 Long Time supply	支持小量 NO MOQ	品种齐全 In Full Range	

9. Cautions and Handling Precautions

9.1 Handling and Operating the Module

- (1) When the module is assembled, it should be attached to the system firmly.
Do not warp or twist the module during assembly work.
- (2) Protect the module from physical shock or any force. In addition to damage, this may cause improper operation or damage to the module and back-light unit.
- (3) Note that polarizer is very fragile and could be easily damaged. Do not press or scratch the surface.
- (4) Do not allow drops of water or chemicals to remain on the display surface.
If you have the droplets for a long time, staining and discoloration may occur.
- (5) If the surface of the polarizer is dirty, clean it using some absorbent cotton or soft cloth.
- (6) The desirable cleaners are water, IPA (Isopropyl Alcohol) or Hexane.
Do not use ketene type materials (ex. Acetone), Ethyl alcohol, Toluene, Ethyl acid or Methyl chloride. It might permanent damage to the polarizer due to chemical reaction.
- (7) If the liquid crystal material leaks from the panel, it should be kept away from the eyes or mouth. In case of contact with hands, legs, or clothes, it must be washed away thoroughly with soap.
- (8) Protect the module from static; it may cause damage to the CMOS ICs.
- (9) Use finger-stalls with soft gloves in order to keep display clean during the incoming inspection and assembly process.
- (10) Do not disassemble the module.
- (11) Protection film for polarizer on the module shall be slowly peeled off just before use so that the electrostatic charge can be minimized.
- (12) Pins of I/F connector shall not be touched directly with bare hands.
- (13) Do not connect, disconnect the module in the "Power ON" condition.
- (14) Power supply should always be turned on/off by the item 6.1 Power On Sequence & 6.2 Power Off Sequence

9.2 Storage and Transportation.

- (1) Do not leave the panel in high temperature, and high humidity for a long time.
It is highly recommended to store the module with temperature from 0 to 35 °C and relative humidity of less than 70%
- (2) Do not store the TFT-LCD module in direct sunlight.
- (3) The module shall be stored in a dark place. When storing the modules for a long time, be sure to adopt effective measures for protecting the modules from strong ultraviolet radiation, sunlight, or fluorescent light.
- (4) It is recommended that the modules should be stored under a condition where no condensation is allowed. Formation of dewdrops may cause an abnormal operation or a failure of the module.
In particular, the greatest possible care should be taken to prevent any module from being operated where condensation has occurred inside.
- (5) This panel has its circuitry FPC on the bottom side and should be handled carefully in order not to be stressed.

Part. No	KD050WVRPA056	REV	V1.2	Page 24 of 25
	常备库存 Stock For Sale	长期供货 Long Time supply	支持小量 NO MOQ	品种齐全 In Full Range

10. Packing

---TBD-----

Part. No	KD050WVRPA056	REV	V1.2	Page 25 of 25
	常备库存 Stock For Sale	长期供货 Long Time supply	支持少量 NO MOQ	品种齐全 In Full Range